

DATA SHEET.

SCRUBBER DRYER.

RA 55|K40



G. Staehle GmbH u. Co. KG
Mercedesstrasse 15
D 70372 Stuttgart
Telefon +49 (0) 7 11/95 44-950
Telefax +49 (0) 7 11/95 44-941
info@columbus-clean.com
www.columbus-clean.com

columbus

POWERFUL SUCTION MOTOR AND PATENTED MOUNTING SYSTEM OF THE SQUEEGEE TOOL: EXCEPTIONAL SUCTION RESULTS.

RA 55|K40

- ❶ The compact mains operated machine, for efficient cleaning performance on small- or medium-sized surfaces.
- ❷ Single-axle design for exceptional manoeuvrability in the smallest areas.
- ❸ The form of the tank as well as the removable squeegee mounting system provide for easy transport up and down stairs, the fold-away operating handle saves storage space.
- ❹ Easy to clean: the recovery tank with sleek inner walls can be opened completely for simple rinsing and disinfection according to HACCP standards.
- ❺ Compact and easy to use with minimal overall machine dimensions and removable squeegee tool.
- ❻ Extremely high brush pressure, the best in its class.
- ❼ Simple operation with just two functional switches.
- ❽ The innovative, patented mounting system of the arch-shaped squeegee tool adapts actively to the movements of the machine and will perfectly pick up without leaving any waste water even on turns.
- ❾ Filter-protected large opening to the solution tank allows for fast refilling.
- ❿ Available in two cleaning widths of 43 cm or 55 cm – for multiple cleaning tasks within the 40-l-class.
- ⓫ DEKRA certified.
- ⓬ And: made in Germany.



The patented mounting system of the squeegee tool

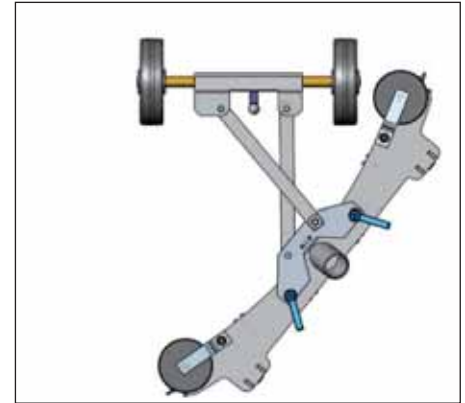

RA 55K40

| | |
|---------------------------|------------------------|
| L x B x H | 1035 x 525 x 815 mm |
| Working width | 550 mm |
| Suction width | 730 mm |
| Theoretical coverage max. | 2200 m ² /h |
| Noise level | 66 dB(A) |
| Empty weight | 70 kg |
| Operating weight | 110 kg |

ELECTRICAL DATA

| | |
|---------------|--------|
| Rated voltage | 230 V |
| Power max. | 1600 W |
| Mains cable | 25 m |

TANK

| | |
|------------------------|------|
| Solution tank capacity | 40 l |
| Recovery tank capacity | 40 l |

SUCTION

| | |
|-------------------|----------|
| Low pressure max. | 204 mbar |
| Air flow max. | 45 l/s |

BRUSHES AND PAD HOLDERS

| | |
|----------------|---------|
| Number | 1 |
| Speed | 150 rpm |
| Brush pressure | 46 kg |

